

Porous metal filter elements.

Strength and precision,
in the design of your choice.



A general overview of Mott precision sintered porous metal filter elements.

Introduction.

Mott Corporation manufactures standard filter elements in a broad range of materials and sizes, and with a selection of fittings, so they can be easily specified with the characteristics and configurations customers require. Mott can incorporate custom features or create completely original designs for specialized needs.

High differential pressure capability – Mott porous metal filter elements can be designed to withstand differential pressures over 3000 psi.

Cleanable filter elements – As part of permanent filtration installations, Mott elements can be effectively cleaned *in situ* in many applications. This is accomplished by a blowback system for gaseous applications or a back-wash/backflush system for liquid applications. Mott engineers are highly experienced in designing and constructing such systems. Examples of these process filters are the LSI filters for liquid/solids applications and the GSV filter for gas/solids applications.

Contaminants can also be removed chemically by means of solvents, caustic wash, acid wash, as well as water, steam and air flush. Ultrasonic cleaning is used to remove chemically inert materials. Controlled-atmosphere fluid bed furnaces may also be used.

Mott precision porous metal filter elements may be cleaned and subsequently kept in continuous operation for years, where other types of elements would have to be replaced several times.

High corrosion resistance – While 316L stainless steel is the standard material of construction, Mott elements are available in a variety of materials for chemical compatibility with many liquids and gases. Other materials include: 304L, 310, 347 and 430 stainless steel; Hastelloy® B, B-2, C-22, C276, N and X; Inconel® 600, 625 and 690; Monel® 400, Nickel 200, Alloy 20 and titanium.

High-Temperature Capability

Material	Atmospheres	
	Oxidizing	Reducing or Neutral
316L SS	750°F	1000°F
310 SS	1100°F	1500°F
Inconel 600	1100°F	1500°F
Hastelloy X	1450°F	1700°F

Performance in reducing or neutral atmospheres is substantially greater due to the inherent strength of the material at elevated temperatures.



Mott precision rolled and welded porous metal elements.

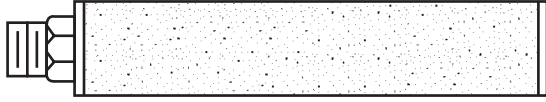

Construction features.

Mott manufactures filtration elements in a wide variety of configurations including open-end, closed-end, and with welded hardware and fittings. Our sales staff and engineers can adapt standard product or customize a design to meet your specific process needs. Contact Mott to review your requirements.

Materials of construction.

Standard materials of construction for rolled and welded elements are 316L stainless steel porous media, with 316 stainless steel hardware. Alternate materials are also available.

Element diameters.

Diameters, other than the standards listed, are available on special order. Consult the factory to discuss your specific requirements. Standard diameters are: 1", 1½", 2", 2½", 2¾" and 3".

Hex nipple open end connections.

Hex nipple sizes, other than the standards shown, are available on special order. Alternate sizes available:

Element Diameter	Standard Hex Nipple	Alternate Hex Nipple Sizes
1"	¼" NPT	½" NPT ¾" NPT
2"	½" NPT	¾" NPT 1" NPT
2½"	1" NPT	1½" NPT 2" NPT
2¾"	1" NPT	1½" NPT 2" NPT
3"	1½" NPT	2" NPT

Smaller sizes may also be specified, if required.

In addition to precision rolled and welded elements, Mott Corporation supplies elements made with Mott seamless porous tube media, which are available in smaller diameters from ¼" to 1" standard, with specials up to 2" diameter.

Rolled and welded porous metal element variables.

Element Diameter	Element Diameter Code
1"	16
1¼"	20
1½"	24
2"	32
2½"	40
3"	48

Mott precision double open end gasket sealed cartridges.

Interchangeable replacement cartridges.

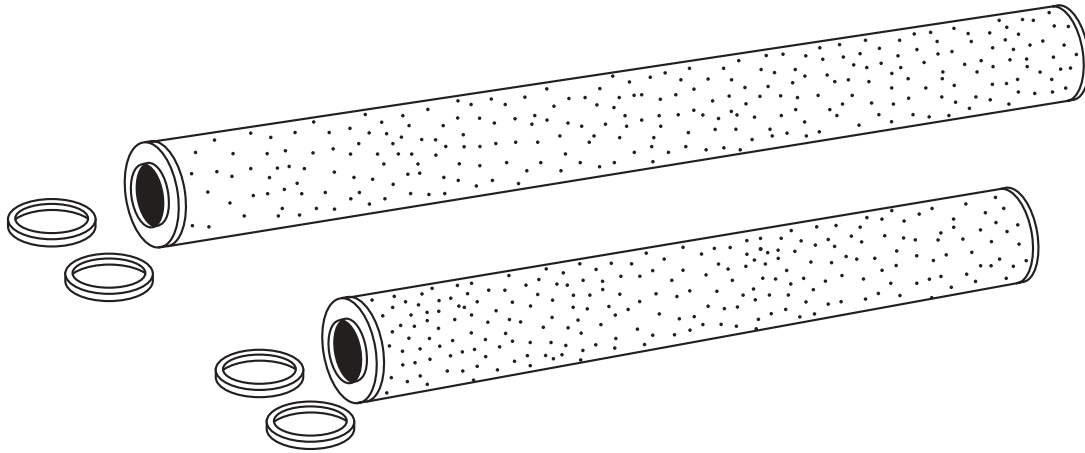

Specifications.

- 2½" diameter
- 10" - 20" - 30" nominal lengths
- 316L stainless steel porous media
- 300 Series stainless steel hardware
- Standard:
 - 0.039" wall media grade 0.2
 - 0.047" wall media grades 0.5, 1
 - 0.062" wall media grades 2, 5, 10, 20
 - 0.078" wall media grade 40
 - 0.093" wall media grade 100
- Media grades in liquid/solids separation applications:
0.2, 0.5, 1, 2, 5, 10, 20, 40, and 100

Maximum differential pressure.

- Standard:
 - Outside-in pressure for media grades 0.2-100 is 50 psi
 - Inside-out* pressure for media grades 0.2-100 is 40 psi
- Spring reinforced "R"
 - Outside-in pressure for media grades 0.2-40 is 250 psi
 - Outside-in pressure for media grade 100 is 150 psi
 - Inside-out* pressure for media grades 0.2-100 is 40 psi

*Inside-out limit due to possible gasket bypass.

Double open end gasket sealed porous metal cartridges – interchangeable cross reference catalog numbers.

**Commercial Filters Division
(CFD and Mott Catalog Numbers are Identical)**

Nominal Lengths		
10"	20"	30"
0.2PY10	0.2PY20	0.2PY30
0.5PY10	0.5PY20	0.5PY30
1PY10	1PY20	1PY30
2PY10	2PY20	2PY30
5PY10	5PY20	5PY30
10PY10	10PY20	10PY30
20PY10	20PY20	20PY30
40PY10	40PY20	40PY30
100PY10	100PY20	100PY30

Cuno Division Poro-Klean

Cuno	Mott
10" Nominal Length	
	0.2PF10
	0.5PF10
	1PF10
	2PF10
50387-01/-06-41-0051	5PF10
50387-01/-06-41-0101	10PF10
50387-01/-06-41-0201	20PF10
50387-01/-06-41-0401	40PF10
	100PF10
20" Nominal Length	
	0.2PF20
	0.5PF20
	1PF20
	2PF20
50387-02/-07-41-0051	5PF20
50387-02/-07-41-0101	10PF20
50387-02/-07-41-0201	20PF20
50387-02/-07-41-0401	40PF20
	100PF20

Pall Trinity Corp.

Pall	Mott
10" Nominal Length	
MCS 1001 PC	100PP10
MCS 1001 PD	40PP10
MCS 1001 PE	20PP10
MCS 1001 PF	10PP10
MCS 1001 PG	5PP10
MCS 1001 PH	2PP10
	1PP10
	0.5PP10
	0.2PP10

**Filterite Division
Dynalloy Porous Cartridges**

Filterite	Mott
10" Nominal Length	
PSC 0.5 x 10	0.2PS10
	0.5PS10
	1PS10
PSC 2 x 10	2PS10
PSC 5 x 10	5PS10
PSC 10 x 10	10PS10
PSC 25 x 10	20PS10
PSC 50 x 10	40PS10
	100PS10
20" Nominal Length	
PSC 0.5 x 20	0.2PS20
	0.5PS20
	1PS20
PSC 2 x 20	2PS20
PSC 5 x 20	5PS20
PSC 10 x 20	10PS20
PSC 25 x 20	20PS20
PSC 50 x 20	40PS20
	100PS20
30" Nominal Length	
PSC 0.5 x 30	0.2PS30
	0.5PS30
	1PS30
PSC 2 x 30	2PS30
PSC 5 x 30	5PS30
PSC 10 x 30	10PS30
PSC 25 x 30	20PS30
PSC 50 x 30	40PS30
	100PS30

**Spring Reinforced Cartridges
(Add R Suffix to Mott Catalog Number)
(Examples: 5PFR10, 2PPR10, 20PSR30, 10PYR20)**

Gaskets (two per cartridge)			
Material	PF & PP CPN	PY CPN	PS CPN
Neoprene	280107-63	280106-63	280111-63
Teflon®	280107-64	280106-64	280111-64
Viton A	280107-65	280106-65	280111-65
Buna N	280107-66	280106-66	280111-66
EPDM*	280107-71	280106-71	280111-71

*Ethylene Propylene

Mott filter elements can be selected and ordered with the exact combinations of sizes, connections, materials and filter ratings that are desired for specific applications. Two series are available: 2200 rolled and welded elements; 2300 seamless elements.



Ordering Information

Element Series	Code	Element Diameter	Code	Open End Connection	Code	Open End Size	Code	Code
2200	22	1/4"	04	NPT Hex Nipple	A	NPT or Pipe (P)		
2300	23	3/8"	06	Female NPT Hex	B	1/8"	02	
		1/2"	08					1/4"
		5/8"	10	NPT Nipple Schedule 40	C*	3/8"	06	
		3/4"	12					1/2"
		1"	16	Venturi NPT Hex Nipple	D	3/4"	12	
		1 1/4"	20					1"
		1 1/2"	24	Plain Pipe Schedule 40	E*	1 1/4"	20	
		2"	32					1 1/2"
		2 1/2"	40	Pipe Socket Weld 3000 # Class	F	2"	32	
		2 9/16"	41					
		2 3/4"	44	Plain Tube	G**	Tube Dia. (D)		
		3"	48					1/8"
		3 1/2"	56	Tube Socket Weld	H	1/4"	04	
		4"	64					3/8"
				Compression Tube Union	J	1/2"	08	
								3/4"
				Straight Thread Metallic Seal Internal Hex Drive	K ^x	1"	16	
								1 1/4"
				Straight Thread O-Ring Seal (Adapts to MS-33649, AND 10049, AND 10050, JIC & SAE ports.)	L	1 1/2"	24	
								2"
				Straight Thread Special	M ^x	Thread (D)		
								7/16"-20"
				Straight Thread Special	N ^x	9/16"-18"	09	1 5/8"-12" 26
								3/4"-16"
				O-Ring Seal Shank	P*	1 1/16"-12"	17	2 1/2"-12" 40
								Nominal Dia.
				Flange Tube Sheet Mount	Q	1/2"	08	1 1/4" 20
								3/4"
				Pipe Flange Mount	R*	1"	16	2" 32
								1 1/4"
				RTJ Pipe Flange Mount	S*	1 1/2"	24	
								Open End

- * Specify length.
- ** Specify length and wall thickness.
- x Specify thread length.
- Specify element flange thickness.

Specifications:
2200—rolled & welded
Sizes 1 1/2—4" dia.

Media Grade	Wall Thickness
0.2	.039"
0.5	.047"
1	.047"
2-20	.062"
40 & 60	.078"
100	.093"

2300—seamless
Sizes 3/8—2" dia.

Element Diameter	Media Grade	Wall Thickness
3/8—3/4"	0.2—20	.062"
3/8—3/4"	40	.078"
3/8—3/4"	100	.093"
1"	All	.125"
> 1"	All	Consult factory

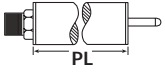

Porous Length	Code	Blind End Configuration	Code	Blind End Size (D)	Code	Media Grade	Code	Material	Porous Media Code	Hardware Code										
		Plain Solid Plain Porous	A	--	00 00*	0.2 0.5	0.2 0.5	316L SS 316 SS	A -	A B										
6"	06	Hex Nut	B	Thrd. 1/4" NOM 3/8" NOM 1/2" NOM	04 06 08	2	2	304L SS	C	C										
10"	10					5	5	304 SS	-	D										
12"	12					10	10	347 SS	E	E										
18"	18					20	20	300 Series SS	-	F										
20"	20					40	40	430 SS	G	G										
24"	24					100	100	Nickel 200	H	H										
30"	30	Stud	C	Dia. x Lg. 1/4" x 1 1/2" 3/8" x 1 1/2" 1/2" x 2"	04 06 08	Other media grade; consult factory		Monel 400	J	J										
36"	36							Inconel 600	K	K										
40"	40							Hastelloy C-276	L	L										
50"	50							Hastelloy X	M	M										
60"	60	Threaded Stud	D	Thrd. x Lg. 1/4-20 x 1 1/2" 3/8-16 x 1 1/2"	04 06			310 SS	P	P										
70"	70							Alloy 20	N	N										
		Hex Head Threaded Stud	E	1/2-13 x 2"	08			Titanium	T	T										
								Hastelloy B-2	U	U										
		Centering Cone (60°)	F	Dia. 1/4" 1/2" 3/4" 1"	04 08 12 16			Hastelloy C-22	V	V										
								Hex Socket (Internal)	G	Hex 1/4" 3/8" 1/2"	04 06 08			Other materials available; consult factory						
														Stabilizer	H	Wd. x Lg. 1 5/16" x 3" 1 5/16" x 7"	21A 21B			

00* * = Porous End Cap

Examples:

2312-A08-06-A00-20-AA

denotes a Series 2300 seamless filter element, 3/4" diameter, with a 1/2" NPT hex nipple open end, 6" porous length, plain blind end, media grade 20 and 316L stainless steel for all components.

2224-N12-18-A00-20-AB (N = 1 1/2" Length)

denotes a Series 2200 rolled and welded filter element, 1 1/2" diameter, with a special 3/4 - 16 straight thread open end, 18" porous length, plain solid blind end, media grade 20, 316L stainless steel porous media and 316 stainless steel hardware.

2244-M24-36-B08-10-GD (M = 2 5/8" Length)

denotes a Series 2200 rolled and welded filter element, 2 3/4" diameter, with a special 1 1/2 - 6 straight thread open end, 36" porous length, 1/2" hex nut on the blind end, media grade 10, 430 stainless steel porous media and 304 stainless steel hardware.



2240-Q42-60-H21A-2-AB

denotes a Series 2200 rolled and welded filter element, 2 1/2" diameter, with a 2 5/8" diameter flanged open end, 60" porous length, 1 7/16" diameter stabilizer 3" long on the blind end, media grade 2, 316L stainless steel porous media and 316 stainless steel hardware.

Typical properties of Hastelloy® C276 filter elements.

Hastelloy C276 Rolled and Welded Filter Element Dimensions

Media Grade	Cartridge Wall Thickness (in.) (±0.005 in.)	Standard Cartridge Diameters (in.)
0.5	0.030, 0.047	1, 2, 2.5, 3
1	0.047, 0.062	1, 2, 2.5, 3
2	0.062	2, 2.5, 3
5	0.062	2, 2.5, 3
10	0.062	2, 2.5, 3

NOTE: Cartridges are welded to make 10" to 80" standard lengths. Other diameters and longer lengths are available.

Hastelloy C276 Seamless Filter Element Dimensions

Media Grade	Cartridge Wall Thickness (in.) (±0.020 in.)	Cartridge Diameters (in.) (+5%; -1%)
0.5	0.062 - 0.125	0.375 - 1.0
1	0.062 - 0.125	0.375 - 1.0
2	0.062 - 0.125	0.375 - 1.0
5	0.062 - 0.125	0.375 - 1.0
10	0.062 - 0.125	0.375 - 1.0
20	0.062 - 0.125	0.5 - 1.0
40	0.078 - 0.125	0.5 - 1.0
100	0.093 - 0.125	0.5 - 1.0

NOTE: Maximum length is 24". Tubes are welded to make longer lengths.

Hastelloy C276 Elements, Air Permeability

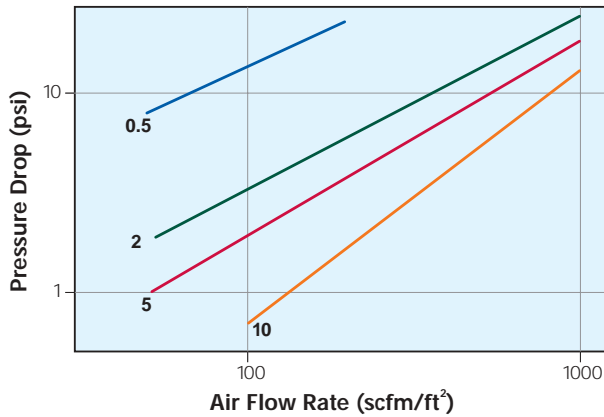

Hastelloy C276 Elements, Water Permeability

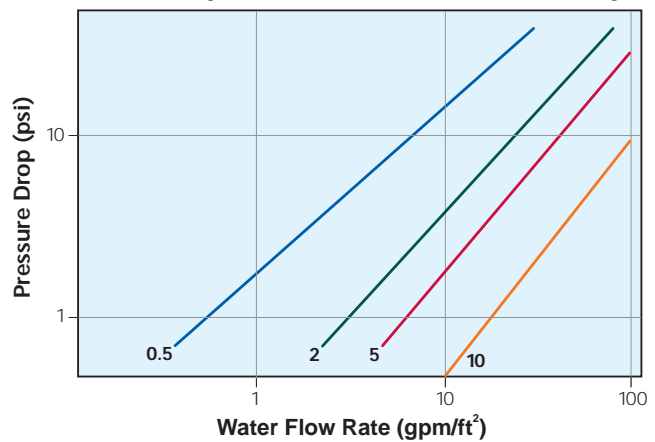

Typical Tensile Properties of Hastelloy C276 Rolled and Welded Filter Elements

Media Grade	0.2% Yield Strength (psi)	Ultimate Tensile Strength (psi)	Percent Elongation	Modulus (Million psi)
0.5	24,000	27,000	1.3	10
2	15,000	17,000	1.3	7
5	10,000	12,000	1.4	5
10	6,500	8,000	1.4	4

NOTES:

- The permeability values may vary ±15%. Tensile properties are typical values.
- Hastelloy C276 porous media may be used up to 1000°F. The maximum service temperature will depend on the environment. Please consult factory for further details.
- The suggested applications of Hastelloy C276 alloy contained in this publication are based on information available in open literature. Mott Corporation does not make any warranties or assume any legal liability for its accuracy, completeness or usefulness.

Typical Applications of Hastelloy C276

- Bleach plants in Paper and Pulp Industry
- Components exposed to sour gas
- Flue-gas desulfurization
- Sulfuric acid environment
- Petrochemical plants
- Organic chloride production
- Food processing equipment
- Sea water and brine solutions

Rolled and welded porous metal 1" diameter PDS elements.

Mott Corporation has developed a precision thin media originally for use as porous demineralizer septa (PDS) (0.028" thick) that is rolled and seam welded into 1" diameter cylindrical elements. The unmatched *uniformity of permeability* of Mott media provides excellent filtration performance. This feature is most important in precoat applications, such as with demineralizer resins for boiler feed water. Uniform precoat is assured, providing optimum cycle life. In actual experience at a nuclear power plant, Mott PDS elements had a 10 times longer cycle life than that of a competitive media.

Type Q17-1" Diameter Element
Flanged Tube Sheet Mount
O-Ring Seal
PDS Media
316L Stainless Steel Porous Media
304 Stainless Steel Hardware

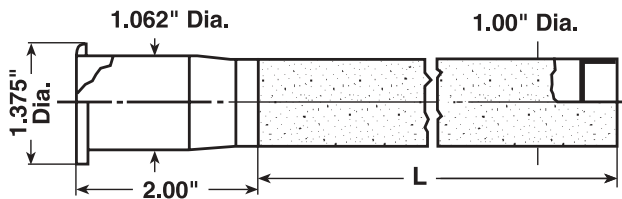

Tube sheet construction.

Hole for Element – 1.070" +0.010/0.000 diameter.
0.015" x 45° chamfer maximum.
Tube sheet surface for O-Ring seal, 1.5" diameter around element hole to be 125 RMS or better.

The standard mounting is an O-Ring seal flange, designated as -Q17-. Elements are top loaded and secured into the tube sheet by a hold down plate (see Tube Bundle Assembly below). PDS elements provide a reliable, light-weight alternative to 1" diameter heavy wall seamless tube elements.

O-Ring seal material.

Neoprene
Teflon®
Viton
Buna-N
Ethylene Propylene (EPDM)
Silicone
Kalrez®
Teflon® Encapsulated Viton

Tube bundle assembly.

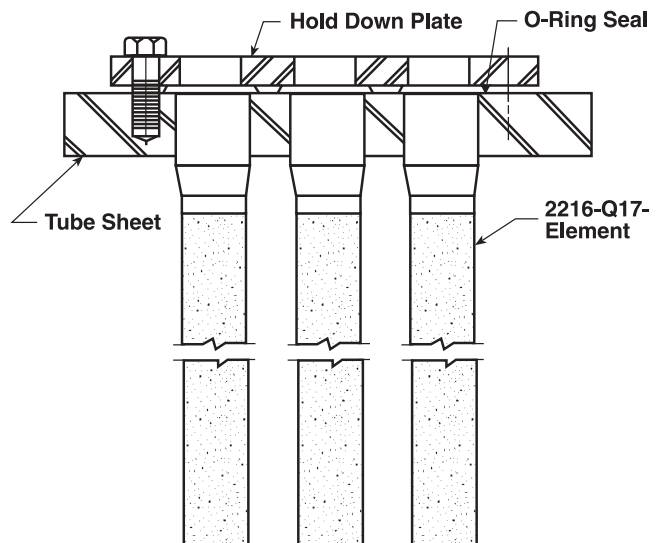

The cleaning of Mott porous metal filter elements.

Cleaning of Mott porous metal filter elements can be accomplished in two ways: *in situ* (in place) cleaning or *removal* of elements from their housings for cleaning.

In situ cleaning in liquid/solids systems can be accomplished by backwashing and, in gas/solids systems, by blowing back. In either case, if the filtration processes are designed to operate within specific parameters, the systems will provide extended on-stream life with effective solids recovery. The backwash or blowback methods are specific to each application, and can offer many process options. In addition, *in situ* chemical cleaning can be done using solvents or detergents, followed by rinses with a fluid compatible with the process.

Cleaning filter elements by removing them from the system can be done by several methods: Chemical cleaning with compatible solvents, ultrasonic cleaning of insoluble solvents and controlled temperature/atmosphere fluid bed cleaning. Multiple cleanings of Mott porous metal elements is common.

Do not mechanically clean porous metal elements. Wire brushing, scraping, sand or glass bead blasting can smear the pores and close off the porous media.

Chemical cleaning of porous elements.

Chemical cleaning follows a logical sequence. First, determine what contaminants are present in the filter. Next, determine the chemical agents that will dissolve these contaminants (without dissolving or attacking the porous metal). The chemical agents compatible with 316L stainless steel porous media include, but are not limited to:

- Water at any temperature
- 15% nitric acid at up to 150°F
- 20% caustic up to 212°F
- Alcohols
- Acetic acid
- Acetone
- Ammonia
- Organic solvents
- Methylene chloride
- Industrial cleaners such as Oakite 31 or Sonicor #103 (to remove grease)
- Solvents and detergents

Soak the elements in the chemical agent as required, flush with clean, filtered water or other compatible fluid, blow out with clean air or steam. Two chemical agents may be required, such as 15% nitric acid to remove iron oxide and 20% caustic to remove aluminum particulate, with a water flush between soaks.

Other methods of cleaning porous metal media.

To remove inert or insoluble solids from porous metal elements, ultrasonic cleaning is an effective process. The fluid medium usually contains a detergent for maximum removal efficiency. It is recommended that ultrasonic transducers provide at least 60 watts per gallon of fluid in the ultrasonic bath. Cleaning may require from 10 to 60 minutes. Optimal results are obtained when the cleaning solution is flowed through the element in the reverse direction during ultrasonic cleaning.

For elements used for gas/solids service, it is necessary to bake the elements in an oven at 300°F to 400°F after cleaning to ensure that all moisture is removed from the elements.

Controlled atmosphere fluid bed cleaning is a very specialized process. Manufacturers of fluid bed cleaning equipment should be contacted to discuss the specific cleaning requirements.

Evaluation of cleaning effectiveness.

To evaluate the effectiveness of cleaning and the integrity of the filter elements, it is necessary to air flow test, and leak and/or bubble point test the elements after cleaning. For post-cleaning evaluation to be meaningful, new elements should be serialized and "base lined", with air flow and bubble point data recorded before they are put into service. This provides a basis for comparison and evaluation.

Air flow testing determines the differential pressure through the media at a given air flow, usually set at 2 scfm/ft². After cleaning, the differential pressure at the same air flow may be only slightly higher than the "base line" value; a 10-15% increase is generally accepted as clean. A significantly higher differential pressure indicates ineffective cleaning. A second cleaning may be required.

Bubble point testing, or leak testing, is a measure of integrity of a filter element or cartridge. Bubble point testing is the determination of the actual bubble point or "first bubble" of an element. Leak testing determines whether there are any "leaks" in an element at a pressure below the minimum bubble point for the particular porous media being tested. Each Mott filter grade has a specific bubble point range which is used as the basis for bubble point or leak tests.

Another factor for evaluating filter cleaning is weight, "before and after". Record the weight of the new element on a precision scale and the weight of the element after cleaning and drying to determine the effectiveness of the cleaning. A higher weight indicates contaminants have remained in the filter media. Lower weight could indicate weight loss due to corrosion. The same weight indicates that the filter is free of contaminants.

Typical applications for Mott porous metal filter elements.

Mott can be your Solution Provider.

This applications list is a quick review of the varied uses that have been developed for Mott precision porous metal filter elements. Use this list as a handy reference, coupled with the unique design properties of porous media, to see how Mott products can solve problems for you.

Mott porous media and metal filter elements are widely used in a range of industries:

Chemical/Petrochemical

- Corrosive liquids and gases
- Air, nitrogen, carbon dioxide, argon, helium, ammonia
- Process steam
- Oxygen (filters cleaned for O₂ service)
- Solvents, ketones, esters, amines, liquid hydrocarbons, polymers
- Feedwater and make-up water
- High-temperature liquids, gases
- High-pressure ethylene gas
- Cryogenic fluids
- Ethylene glycol
- Catalyst retention, fluid bed reactors
- Catalyst recovery, slurry phase reactors
- High-efficiency solids recovery or liquid recycling

Refinery

- Filtration of FCCU slurry oil

Electronics

- Filtration of oxide slurries for magnetic tapes
- Filtration of ink for high-speed printers

Pollution control/Monitoring

- High-temperature stack gas sampling
- Probe filters for gas and liquid analysis
- Sampling filters for gas and liquid chromatography
- Wastewater and process effluent filtration

Food/Beverage

- Oxygen stripping
- Aeration
- Carbonation
- Hydrogenation
- Clarification
- Flotation
- Vacuum molds
- Process steam filtration
- Catalyst recovery from hydrogenation reactors
- Polishing of syrups, liquors and other liquids
- Sparging (gas/liquid contacting)
 - Nitrogen sparging for
 - Dewatering oil
 - Deoxidizing wines and other products
 - Bulking mayonnaise and salad dressings

Power generation

- Porous metal septa for powered resin filter/demineralizers
- Condensate polishing



Established in 1959, Mott Corporation coordinates engineering, sales, service and manufacturing from two adjacent facilities totalling 90,000 square feet. Mott's skilled workforce, along with strategically located overseas affiliates, services thousands of customers all over the world, in virtually every major segment of industry.

Need a product? Need advice?

Call us either way. Whether you need a stock solution, a customized design, or simply guidance, we welcome your call. Contact the experts at Mott Corporation today.

mott corporation

84 Spring Lane, Farmington, CT 06032-3159
www.mottcorp.com, email: quest@mottcorp.com
860-747-6333 Fax 860-747-6739

ISO 9001 CERTIFIED
PSELEMENT Rev 1 05/08 2.5M